

# DONKO

## BICYCLE TRANSMISSION



# HISTORY OF CREATION



# SINGLE-SPEED SYSTEMS

## BENEFITS:

- High ease of maintenance
- Maximum reliability
- Low price

## DISADVANTAGES:

- The range of applicability of such a drive is very narrow



# WITH EXTERNAL SWITCHING

## BENEFITS:

- Very wide range of transmission ratios.
- Relatively high efficiency.
- Ability to shift gears under load.
- Low weight.
- Good maintainability in the field.

## DISADVANTAGES:

- Need for regular adjustment, inspection, lubrication and replacement of a number of components.
- Poor performance in the absence of maintenance.
- Poor performance in very dirty conditions.
- Presence of “prohibited” gear combinations.



# PLANETARY BUSHING

## BENEFITS:

- Low maintenance (including lubrication and replacement of parts) and low maintenance skills.
- Possibility to shift gears without pedaling.
- High reliability in utilitarian applications (mud, rain, but light loads).
- High service life of chains and sprockets.

## DISADVANTAGES:

- Low efficiency.
- Relatively high price.
- Large weight.
- Low reliability at high loads, almost complete unsuitability for extreme loads.
- Narrow range of transmission ratios for inexpensive bushings.
- Inability to be repaired in the field.



# PINION TRANSMISSION

## DISADVANTAGES:

- Price!!!



We bring to your attention a new, patent-protected  
4-speed DONKO bicycle transmission.  
This is one of the five most efficient transmissions  
in the history of bicycles.



# DONKO - MADE IN UKRAINE

---

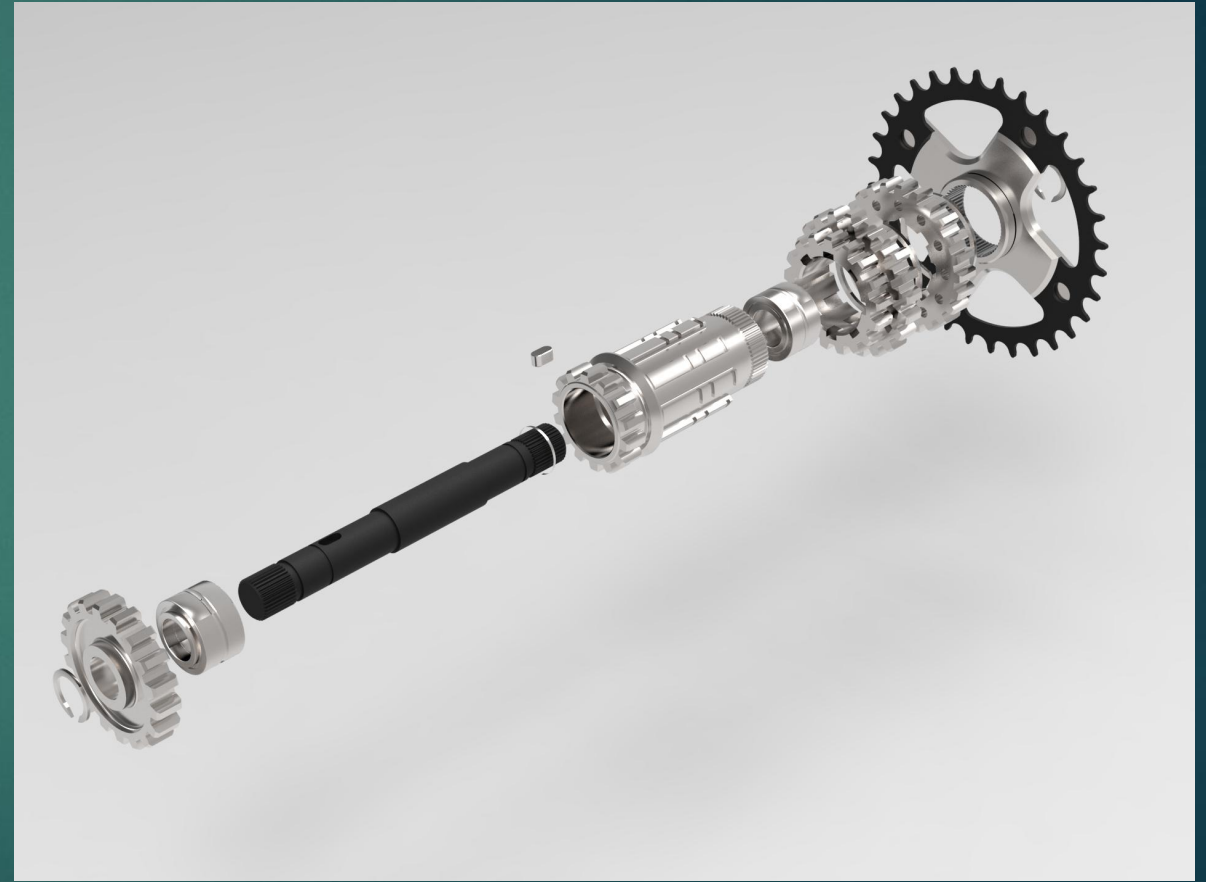
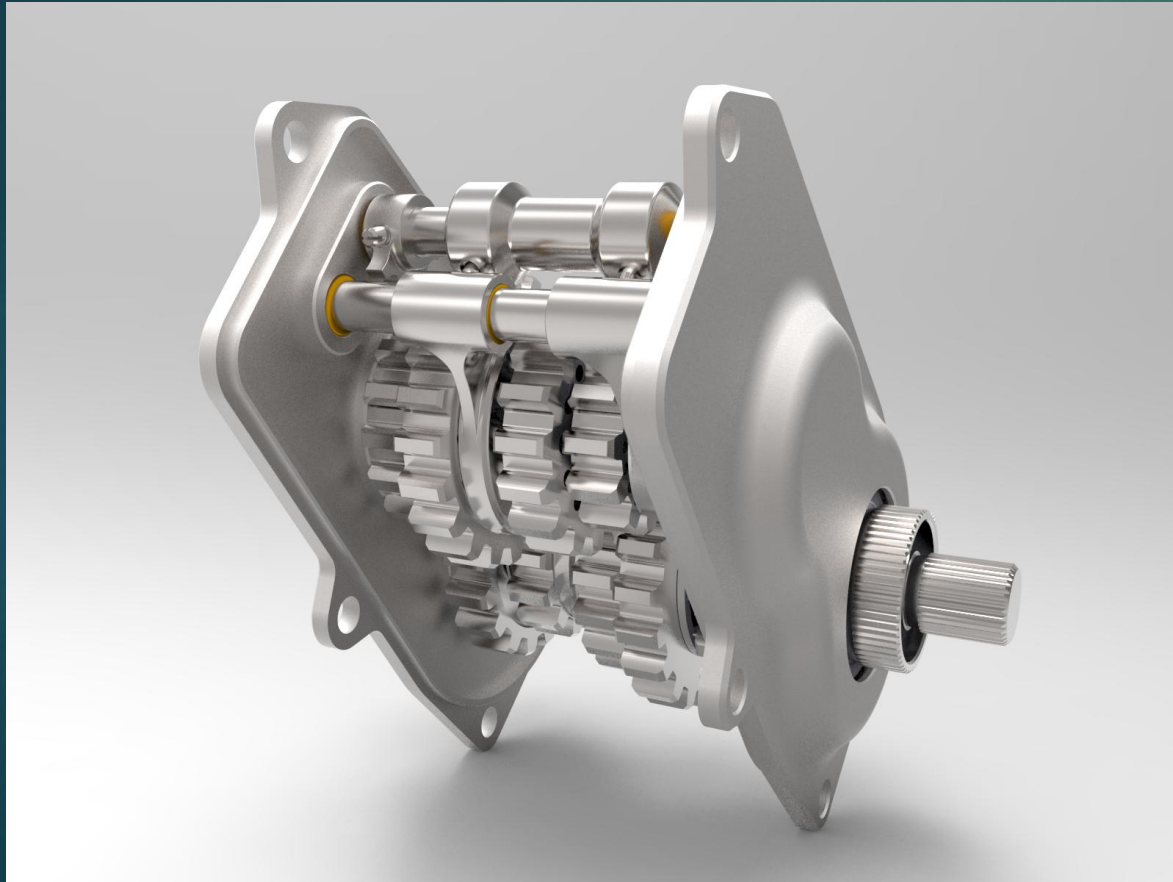

# EASE OF CONTROL

- ✓ The ability to instantly change gears and brake by applying pedal force in the opposite direction, just like a regular road bike, without learning any driving skills.
- ✓ This method of braking is reflexively the most comfortable for a significant number of ordinary cyclists, especially women





# PROTECTION - AVAILABILITY - RELIABILITY

- ✓ The transmission is placed in a durable sealed housing integrated into the base of the bicycle frame and is reliably protected from external destructive factors
- ✓ Technological simplicity, which allows you to quickly establish mass production at a competitive price
- ✓ Reliability and durability of a regular road bike, which will allow you to operate the bike for years without the need for constant maintenance inherent in sports bikes

# DONKO - MADE IN UKRAINE

---

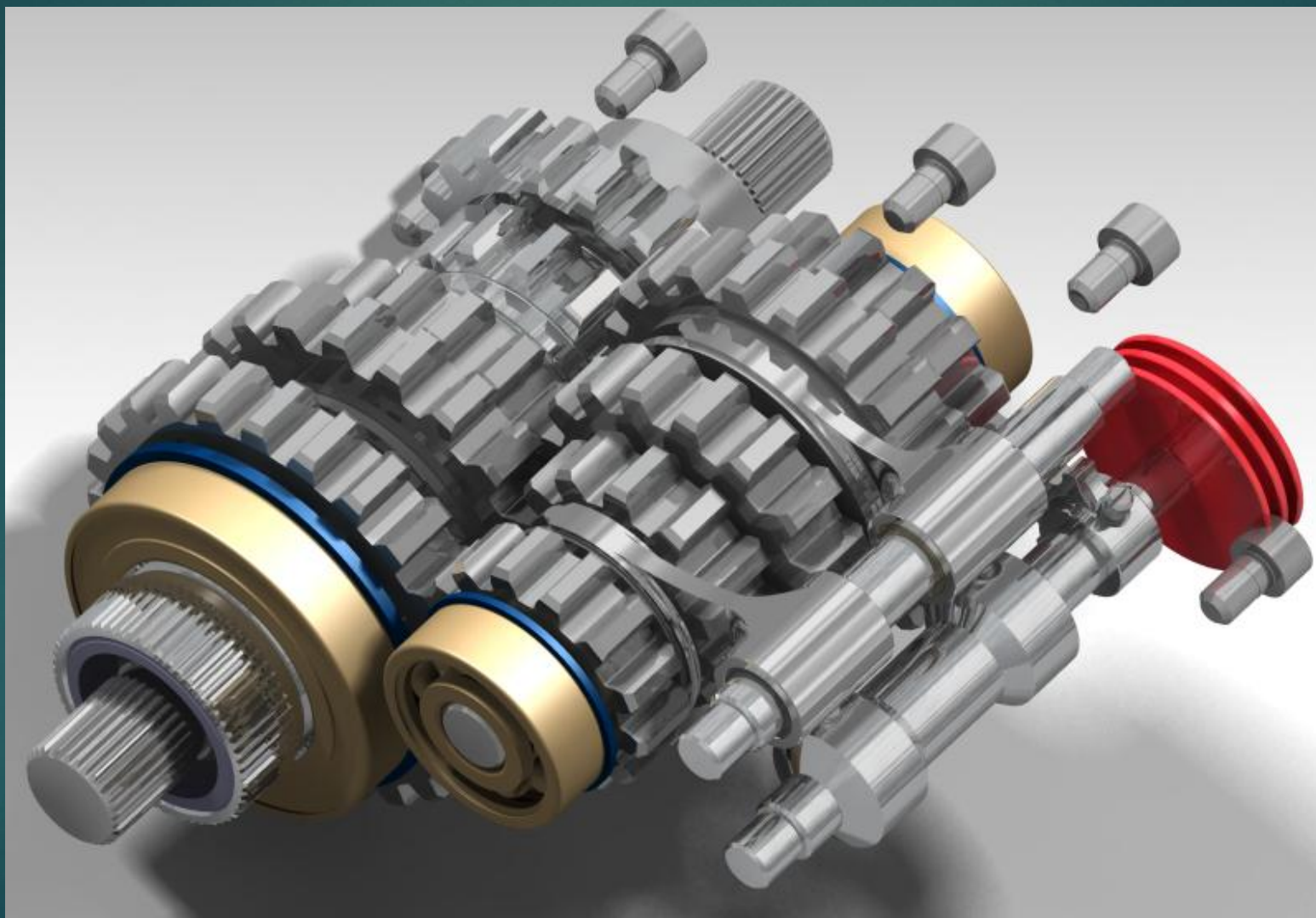

The main areas of application of the DONKO transmission are:



CITY BICYCLES

CARGO BICYCLES



# The main areas of application of the DONKO transmission are:



TOURING BICYCLES

## VELOTRICKSHI



If you need a bike for easy, comfortable and safe walks, DONKO is the perfect solution. And the long service life will allow several generations to use this Ukrainian product.



<https://sis.nipo.gov.ua/en/search/detail/1275960/>



# Thank you all for your attention!

**CONTACT PERSON: YURIY DONCHENKO**

TEL: +38(096)554-8341

URADONKO3@GMAIL.COM

WWW.DONKOLAB.COM

